

DELHI DEVELOPMENT AUTHORITY
QUALITY CONTROL CELL

EE (QC) (3)/DDA/Circular/2004/ 17

Dt 17-1-05

CIRCULAR NO 151

It has been observed that paver blocks pavements are being provided in large number of works in DDA but no relevant specification/codes regarding the quality of paver blocks and laying of paver blocks are incorporated in the Agreements. Thus in the absence of any specification on paver blocks, the contractual disputes can't be ruled out. Technical Sanctioning Authority also do not have standard practice for design of such pavements, as, so far, no approved guidelines/ codes were in vogue.

Now, IRC Special Publication 63-2004 i.e. "Guidelines for the use of interlocking concrete block pavements" has been published by Indian Roads Congress which can be referred by the Field/Planning Units for reference and guidance.

Further, in order to avoid contractual problems EM, DDA desired to compile specification for interlocking concrete block pavements and test procedure etc. for incorporating the same in future NITs and getting the work executed accordingly. The same have been drafted/compiled and sent herewith for incorporating in future NITs and quality control tests etc. may be followed meticulously.

Encl: - As above (Page 1 to 20)

(Er A.P.SINGH)
CHIEF ENGINEER (QC)
DDA. 17-1-05

Copy to:-

- 1 OSD to VC, DDA for kind information of the latter.
- 2 PS to EM, DDA for information of the latter.
- 3 All CEs/DDA, for information and for circulation among their SEs & EEs.
- 4 Director (Hort.) North & South.
- 5 Director (MM). PM/FOMC, Gr.-I

CE (QC)/DDA. 17-1-05

SPECIFICATIONS FOR INTERLOCKING CONCRETE BLOCK PAVEMENT

- 1.0** The interlocking concrete blocks for the pavement shall be procured of the approved shape, size and colour from the reputed manufacturers having facilities of production of design mix concrete, vibro-compacting machine of required specification and well established laboratory for conducting the required tests. The approval shall be obtained from the engineer-in-charge in writing well before the procurement action by the agency.
- 2.0** The engineer-in-charge reserves the right to inspect the manufacturing plant, manufacturing process and to collect the samples at factory or work site and get it tested in the Laboratory of his choice to his entire satisfaction. The testing charges payable if any shall be borne by the contractor.
- 3.0** Unless otherwise specified in the nomenclature of items or in the drawing the concrete paving block, shall conform to the grade(s) as specified in **Table 1** hereunder for various uses.
- 4.0** All paver block, shall be sound and free of cracks or other visual defects which will interfere with the proper paving of the unit or impair the strength or performance of the pavement constructed with the paver blocks. Minor defects in the form of chippings, resulting from the customary methods of handling during delivery, not larger than 10 mm in not more than 5% of consignment shall not be deemed grounds for rejection.

5.0 Sampling for Testing:

- 5.1** The paver blocks required for carrying out the tests laid down in this standard shall be taken by one of the methods given in 5.2 and 5.3 In either case, a sample of 20 blocks shall be taken from every consignment of 4000 blocks or part thereof of the same size, shape and thickness, and the same batch of manufacture. From these samples, the blocks shall be taken at random for conducting the tests.
- 5.2** The required number of paver blocks shall be taken at regular intervals during the loading of the vehicle or the unloading of the vehicle depending on whether sample is to be taken before delivery or after delivery. When this is not practicable, the sample shall be taken from the stack, in which case the required number of blocks shall be taken at random from across the top of the stacks, the sides accessible and from the interior of the stacks by opening trenches from the top.

- 5.3 Each designated section or part thereof in a consignment of blocks shall be divided into ten real or imaginary, approximately equal, group. Two blocks from each group shall be randomly selected for testing.
- 5.4 The sample paver blocks shall be marked for future identification of the consignment it represents. The blocks shall be kept under cover and protected from extreme conditions of temperature, relative humidity and wind till they are required for test. The test shall be undertaken as soon as practicable after the sample has been taken.
- 5.5 All the 20 paver blocks shall be inspected for visual defects. Out of the 20 blocks, 10 blocks shall be subjected to the test for measurement of dimensions, chamfer, aspect ratio, plan area, wearing surface area and deviation from squareness and, in the case of two layer blocks, for measurement of the thickness of the wearing layer. Out of these 10 blocks, 5 blocks shall be subjected to tests for water absorption, block density and compressive strength, in that order. The remaining 5 blocks in this group of 10 shall be subjected to flexural strength test, and remaining if the blocks are used for road pavement carrying vehicular traffic.

6.0 Acceptance Criteria

The lot shall be considered as conforming to the requirements of the specification if the following conditions are satisfied:-

6.1 Dimensions & tolerances:

The recommended dimensions and tolerances for Type A, B and C paver blocks, measure as per "Annexure B" are given in Table 2. Among the sampled 20 blocks the number of blocks with visual defects outside the tolerance limit shall not be more than three.

6.2 Water absorption:

Water absorption, being average of the five units, when determined in the manner described in "Annexure C" shall not be more than 5% by mass.

6.3 Block density:

The block density of concrete pavers, being average of five units, determined in the manner described in "Annexure.D", shall not be less than 2200 Kg/m³.

6.4 Compressive strength:

The concrete block when tested for compressive strength as per method specified in "Annexure.E" shall conform to the requirement and tolerances for different grades as given in Table 3.

6.5 Flexural strength:

The flexural strength the block, shall not be less than 4.0 Mpa when tested as per method specified in "**Annexure F**"

6.6 Abrasion Resistance:

The abrasion index of the paver blocks sample determined by method specified in "**Appendix G**" shall conform to the values given in **Table 4**.

7.0 Marking:

Concrete paver blocks manufactured in accordance with laid down specification shall be marked permanently with the following information:

- a) the identification mark of manufacturer ;
- b) The grade of concrete used for manufacturing of paver blocks.

8.0 For detailed guidelines for the use of interlocking concrete block pavement IRC: SP: 63-2004 may be referred to.

9.0 Technical specifications for laying concrete paving blocks are available in **Annexure "A"**.

10.0 Payment

The finished area shall be measured nearest to 0.01 sqm. for the purpose of payment. The payment for edge restraint shall be made separately which shall be measured on per cum. basis.

Table 1: Recommended grade of concrete for production of paver blocks

Concrete classification	Grade Designation	Specified Characteristic Compressive Strength of 150mm cubes at 28 Days (N/mm ²)	Recommended Use for Production of Blocks For Application Under Traffic Category	Typical Examples of Application
Standard Concrete	M-25- M-30	25-30	Non-Traffic	Building Premises, Monument Premises, Landscapes, Public Gardens/ Parks, Embankment Slopes, Sand Stabilisation etc.
	M-30- M-35	30-35	Light	Pedestrian Plazas, Shopping Complexes, Ramps, Dairy Farms, Car Parks, Office Driveways, Housing Colonies, Office Complexes, Rural Roads ,Farm Houses, Beach Sites, Tourist Resorts etc.
	M-35- M-45	35 - 45	Medium	City Streets, Small and Medium Market Roads, Low Volume Roads, Utility Cuts on Arterial Roads Service Stations etc.
	M-45- M-59	45 - 59	Heavy	Bus Terminals, Industrial Complexes, Mandi Houses, Roads on Expansive Soils, Factory Floors and Pavements etc.
High Strength Concrete	M-60 And Above	60 And Above	Very Heavy	Container Terminals, Ports, Dock Yards, Mine Access Roads, Bulk Cargo Handling Areas, Airport, Pavements etc.

Notes

1. Non-traffic areas are defined as areas where no vehicular or pedestrian traffic occurs.
2. Light traffic is defined as a daily traffic of up to 150 commercial vehicles exceeding 30 KN laden weight, or an equivalent of up to 0.5 million standard axles (MSA) for a design life of 20 years (A standard axle is defined as a single axle load of 81.6 KN).
3. Medium traffic is defined as a daily traffic of 150 to 450 commercial vehicles exceeding 30 KN laden weights, or an equivalent of 0.5 to 2.0 MSA for a design life of 20 years.
4. Heavy traffic is defined as a daily traffic of 450 to 1500 commercial vehicles exceeding 30 KN laden weights, or an equivalent of 2.0 to 5.0 MSA for a design life of 20 years.
5. Very heavy traffic is defined as a daily traffic of more than 1500 commercial vehicles exceeding 30 KN laden weights, or an equivalent of more than 5 million MSA for a design life of 20 years.

Table 2: Recommended dimensions and tolerances for type A, B and C paver blocks.

S.No.	Dimension	Measurement Method	Recommended Values	Tolerance Limit
1.	Width, W	As per Annex B	80 to 115 mm	± 2 mm
2	Length, L	As per Annex B	(1.5 to 2.3) X W	± 2 mm
3	Thickness, T	As per Annex B	60 to 120 mm	± 3 mm
4	Aspect Ratio (L/T)	As per Annex B	Maximum: 4.4	+ 0.275
5	Chamfer	As per Annex B	Maximum: 5mm	+ 1 mm
6	Thickness of Wearing Layer	As per Annex B	Minimum:15mm	- 2mm
7	Plan Area, Asp.	As per Annex B	Maximum:0.03m ²	+0.001m ²
8	Wearing Surface Area, A _{sw}	As per Annex B	75% of plan Area	$\pm 1\%$
9	Squareness	As per Annex B	Nil	± 2 mm

Table 3 Compressive strength requirements of concrete paver blocks.

S.No.	Grade of Concrete	28-day Compressive Strength (MPa) of Chamfered Paver Blocks of Thickness			
		60mm	80mm	100mm	120mm
1	M-25	26.5	29.5	31.0	32.5
2.	M-30	31.8	35.4	37.2	39.0
3	M-35	37.1	41.3	43.4	45.5
4	M-40	42.4	47.2	49.6	52.0
5	M-45	47.7	53.1	55.8	58.5
6	M-50	53.0	59.0	62.0	65.0
7	M-55	58.3	64.9	68.2	71.5
8	M-60	63.6	70.8	74.4	78.0

Note: A 10 percent lower tolerance limit in compressive strength shall be allowed.

1. TECHNICAL SPECIFICATIONS FOR LAYING CONCRETE PAVING BLOCKS

1.1. Base

1.1.1. The Finished surface of the concrete base shall match the design profile of the concrete blocks within ± 10 mm.

1.1.2. Compaction shall be done with vibratory roller. In restricted areas where normal rollers cannot operate, hand-held or plate vibrators should be employed.

1.2. Bedding Sand Layer

1.2.1. The bedding sand layer shall be from either a single source or blended to achieve the following grading.

<i>IS Sieve Size</i>	<i>Per cent Passing</i>
9.52 mm	100
4.75 mm	95-100
2.36 mm	80-100
1.18 mm	50-95
600 micron	25-60
300 micron	10-30
150 micron	0-15
75 micron	0-10

Single sized, gap-graded sands or those containing an excessive amount of fines will not be used. The sand particles should preferably be angular type.

The joint-filling sand should pass a 2.35 mm sieve and be well graded. The following grading is recommended:

<i>Sieve Size</i>	<i>Per cent Passing</i>
2.36 mm	100
1.18 mm	90-100
600 micron	60-90
300 micron	30-60
150 micron	15-30
75 micron	0-10

The use of cement in the joint-filling sand is not recommended as a general practice as the cemented sand is likely to crack into segments which are easily dislodged.

1.2.2. Average thickness of this laying course shall be 20 to 40 mm.

1.2.3. The sand should be slightly moist, and the moisture content shall be about 4 per cent by weight.

1.2.4. It should contain not more than 3 per cent by weight of clay and silt and the materials shall be free from deleterious salts or contaminates.

1.2.5. The finished surface of the bedding layer shall match exactly the design profile as indicated on the drawings.

1.2.6. Before placing the bedding layers, the surface of concrete should be cleared by sweeping.

1.2.7. Walking or driving on the finished surface of the bedding layer shall not be permitted.

1.3. Concrete Paving Blocks

1.3.1. Laying of the blocks shall be done, precisely at the indicated level and profile and in a way that a good surface draining to the gulley chambers is assured.

1.3.2. Around gulley chambers and inspection pits the pavement shall have a level of 5 mm higher than the above mentioned elements.

1.3.3. The blocks shall be laid to the pattern directed by the Engineer or the pattern recommended by the designer. The blocks shall be laid as tight as possible to each other. The maximum joint width shall be limited to 4 mm.

1.3.4. Laying of broken blocks is not allowed except along connections or edges. The maximum length of a purpose broken block is 100 mm. Breaking of the blocks shall be done with a "block splitter" or a mechanical saw.

1.3.5. Fine angular sand as per specification shall be brushed into the joints, and thereafter compaction shall be done with a vibrating plate compactor on a clean surface. After compaction, again fine angular sand shall be brushed into the joints.

1.4. Surface Tolerances

1.4.1. Surface tolerance for finished surface shall be ± 10 mm from the design level.

1.4.2. The surface tolerance for base course shall be in the range of 0 to +10 mm from nominated level and 10 mm deviation from a 3 m straight edge.

1.4.3. The surface tolerance for sub-base shall be within 0 to -20 mm of nominated level.

2. FIELD/LABORATORY TESTS

- (a) Necessary field/laboratory tests shall be carried out by the contractor while executing the work at his own cost.
 - (b) The field/laboratory tests may be conducted in an Engineering College/ approved technical institution as directed by the Engineer.
-

"ANNEX B"**METHOD FOR DETERMINATION OF DIMENSIONS, ASPECT RATIO, PLAN AREA, WEARING SURFACE AREA AND DEVIATION FROM SQUARENESS.****B-1 DETERMINATION OF LENGTH, WIDTH, THICKNESS AND ASPECT RATIO****B-1.1 Apparatus**

The apparatus shall comprise:

- a) Steel calipers;
- b) A steel rule capable of measuring up to 300 mm to an accuracy of 0.5 mm

B-1.2 Specimens

Ten paver block specimens, randomly selected from the group of blocks of specified shape, size and thickness, as per the sampling procedure in 5, shall be tested.

B-1.3 Procedure

B-1.3.1 Length and Width: The length and width of a paver block (Fig.3) shall be measured across two opposite faces by using the steel calipers or steel rule. Two representative positions shall be used for measurement of length and three for measurement of width. The mean values of length and width for the block shall be noted to the nearest 1 mm.

B-1.3.2 Thickness: The thickness of a paver block (Fig. 3) shall be measured at four sensibly different representative positions. The mean value of the thickness of the block shall be noted to the nearest 1 mm.

B-1.3.3 Aspect Ratio: The Aspect Ratio of the specified block shall be calculated by dividing the mean length by the mean depth as determined by the procedures in B-1.3.1 and B-1.3.2 and shall be noted to the nearest 0.1

B-2 CHAMFER**B-2.1 Apparatus**

The apparatus shall comprise of steel calipers.

B-2.2 Specimens

The ten paver block specimens, tested for dimensions as per B-1, shall be tested.

B-2.3 Procedure

The depth and width of chamfer of the paver block (Fig.3) shall be measured across two opposite faces, to the nearest 0.1 mm, by using the steel calipers. Four representative positions shall be used for measurement of depth and width. The mean values of depth and width of chamfer for the block shall be noted to the nearest 0.1 mm

B-3 PLAN AREA AND WEARING SURFACE AREA

B-3.1 Apparatus

The apparatus shall comprise:

- (a) Balance capable of weighing 100 g to an accuracy of 0.01 g;
- (b) Sheets of thin cardboard of uniform thickness;
- (c) Sharp pencil;
- (d) Odd-leg marking gauge (Fig.4);
- (e) Sharp scissors;
- (f) Steel rule marked with graduations of 0.5 mm.

B-3.2 Specimens

The ten specimens, tested for dimensions as per B-1, shall be used for the tests.

B-3.3 Procedure

B-3.3.1 Plan Area (A_{sp}): The block shall be placed, wearing surface facing up, on the card board and its perimeter traced with the pencil. The shape shall be cut out accurately with the scissors and weighed to the nearest 0.01 g, and the result recorded as mass m_{sp} . A rectangle measuring 200 mm X 100 mm, accurately cut out from the same cardboard, shall also be weighed to the nearest 0.01 g, and the result recorded as mass m_{std} . The plan area for the block shall be calculated from the formula:

$$A_{sp} = \frac{20,000 m_{sp}}{m_{std}}, \text{ mm}^2$$

Alternatively, where possible, the plan area may also be calculated by multiplying the length by the width, as determined by the procedure in B-1.3.1

B-3.3.2 Wearing Surface Area (A_{sw}): The width of the chamfer of the block shall be measured at four sensibly different locations and their mean value determined. A ball-point pen refill shall be fixed to the odd-leg marking gauge and the gauge shall be set to the measured mean value of chamfer width. The gauge so set shall be used to draw a line, indicating the width of the chamfer, along the periphery of the cardboard shape of the plan area of the block with mass m_{sp} , as obtained in B-3.3.1. The marked chamfer width on the cardboard shall be neatly cut away with the scissors, and the cardboard shall be weighed to the nearest 0.01 g and the result recorded as mass m_{sw} . The wearing surface area for the block shall be calculated from the formula:

$$A_{sw} = \frac{20,000 m_{sw}}{m_{std}}, \text{ mm}^2$$

B-4 DEVIATION FROM SQUARENESS

B-4.1 Apparatus

The apparatus shall comprise:

- (a) Engineer's square or a profiled template
- (b) Feeler gauges

B-4.2 Specimens

The ten specimens, tested for dimensions as per B.1, shall be used for the tests.

B-4.3 Procedure

With the stock of the square of profiled template in contact with the top or bottoms surface of the block, the blade shall be brought into contact with the vertical face of block. The clearance, if any, between the square of profiled template and the vertical face of the block shall be measured to the nearest 0.1 mm with the feeler gauge at points 10 mm inside each top and bottom edge of the block. This measurement shall be repeated at six sensibly different locations around the block, and the average of the feeler gauge measurement noted as the deviation from squareness for the block, which shall be noted to the nearest 0.1 mm.

B-5 REPORT

The individual and average values of measured dimensions, chamfer, aspect, ratio, plan area, wearing surface area and deviation from squareness of specimens tested as per B-1, B-2, B-3 and B-4 shall be reported.

"ANNEX C"**METHOD FOR DETERMINATION OF WATER ABSORPTION****C-1 APPARATUS**

The balance used shall be sensitive to within 0.5 percent of the mass of the smallest specimen tested.

C-2 SPECIMENS

Five out of the ten test specimens selected for test as per Annex B shall be used for the tests.

C-3 PROCEDURE

C-3.1 Saturation: The test specimens shall be completely immersed in water at room temperature for 24 ± 2 hours. The specimens shall then be weighed, while suspended by a metal wire, and completely submerged in water, and the weight shall be recorded in kg to the nearest 0.001kg. (W_a). They shall be removed from the water and allowed to drain for one minute by placing them on a 10mm or coarser wire mesh. Visible water on the specimens shall be removed with a damp cloth. The specimen shall then be immediately weighed and the weight for each specimen noted in kg to the nearest 0.001 kg. (W_w).

C-3.2 Drying : Subsequent to saturation, the specimens shall be dried in a ventilated oven at $(107 \pm 7)^\circ\text{C}$ for not less than 24 h. and until two successive weighing at intervals of 2 hours show an increment of loss not greater than 0.2 percent of the previously determined mass of the specimen. The dry weight of each specimen (W_d) shall be recorded in kg to the nearest 0.001kg.

C-4 CALCULATION

C-4.1 Absolute Water Absorption (W_{ab}): The absolute water absorption shall be calculated as follows:

$$W_{ab} = \frac{W_w - W_d}{W_w - W_a}, \quad \text{Mg/m}^3$$

C-4.2 Percent Water Absorption ($W\%$): The percent water absorption shall be calculated as follows:

$$W\% = \frac{W_w - W_d}{W_d} \times 100$$

C-5 REPORT

The individual and average values of measured water absorption of specimens tested as per C-1 to C-4 shall be reported.

" ANNEX D"

METHOD FOR DETERMINATION OF DENSITY**D-1 APPARATUS**

- (a) Electric oven
- (b) Weights and Balance of adequate capacity and accuracy

D-2 SPECIMENS

Five specimens tested as per Annex C shall be used for the tests.

D-3 PROCEDURE

D-3.1 The five specimens shall be dried to constant mass in a suitable oven, heated to $(110 \pm 5)^{\circ}$ C. The blocks shall then be taken out and allowed to cool to room temperature. Their dimensions shall be measured in accordance with Annex B and the overall volume completed in m^3 , nearest to $0.001 m^3$. The blocks shall then be weighed in kg to the nearest 0.001 kg.

D-3.2 Alternatively, the volume of the specimens shall be calculated by making use of the data generated during the determination of water absorption (Annex C), as follows:

$$\text{Volume} = (W_w - W_a) 10^3, m^3$$

D-4 CALCULATION

The density of each block shall be calculated as follows:

$$\text{Density} = \frac{\text{Mass of block in kg}}{\text{Volume of block in } m^3} \times 10^{-3} \text{ (Mg/m}^3\text{)}$$

D-5 REPORT

The individual and average values of measured density of specimens tested as per D-1 to D-4 shall be reported.

"ANNEX E"**METHOD FOR DETERMINATION OF COMPRESSIVE STRENGTH****E-1 APPARATUS**

E-1.1 Testing Machine: The apparatus shall comprise a compression testing machine which shall be equipped with two steel bearing blocks for holding the specimen. It is desirable that the blocks have a minimum hardness of 60 (HRC) and a minimum thickness of 25 mm. The block on top through which load is transmitted to the specimen shall be spherically seated. The block below on which the specimen is placed shall be rigidly fitted. When the bearing area of the steel blocks is not sufficient to cover the bearing area of the paver block specimen, two steel bearing plates meeting the requirements of E-1.2 shall be placed between the steel platens fitted on the machine and the specimen.

E-1.2 Steel Bearing Block and Plates : The surfaces of the steel bearing blocks and plates shall not depart from the plane by more than 0.025 mm in any 15 mm dimension. The centre of the sphere of the spherically seated upper bearing block shall coincide with the centre of the bearing surface. If a bearing plate is used, the centre of the sphere of the upper bearing block shall be on a line passing vertically through the centroid of the specimen bearing face. The spherically seated block shall be held closely in its seat, but shall be free to turn in any direction. The diameter of the face of the bearing blocks shall be at least 150 mm. When steel plates are employed between the steel bearing blocks and the specimen, the plates shall have a thickness equal to at least one-third the distance from the edge of the bearing block to the most distant corner of the specimen. In no case shall the plate thickness be less than 12mm.

E-2 SPECIMENS

The five specimens tested as per Annexes C and D shall be used for the tests.

E-3 CAPPING OF SPECIMENS

E-3.1 The bearing surfaces of the specimens shall be capped by one of the methods described in Clauses C-3.1 and C-3.2 of Appendix C of IS: 2185 (Part1)-1979,

E-3.2 Alternatively, 4 mm thick plywood sheets of size larger than the specimens by a margin of at least 5 mm from all edges of the specimen shall be used for capping the specimens.

E-3.3 When blocks with surface relief features have to be tested; their surfaces shall be ground to plainness before capping and testing.

E-4 PROCEDURE

E-4.1 The dimensions and plan areas of the blocks shall be determined as described in Annex B. The blocks shall be stored for 24 ± 4 hours in water maintained at a temperature of $(20 \pm 5)^{\circ}\text{C}$. The bearing plates of the testing machine shall be wiped clean. The specimen shall be clamped between the plates in such a way that the axes of the specimen are aligned with those of the bearing plates.

E-4.2 The load shall be applied without shock and increased continuously at a rate of $15 \pm 3 \text{ N/mm}^2 / \text{minute}$ until no greater load can be sustained by the specimen or delamination occurs. The maximum load applied to the specimen shall be noted in N.

E-5 CALCULATION

The apparent compressive strength of individual specimen shall be calculated by dividing the maximum load (in N) by the plan area (in mm^2). The corrected compressive strength shall be calculated by multiplying the apparent compressive strength by the appropriate correction factor from Table below. The strength shall be expressed to the nearest 0.1 N/mm^2 .

Correction factors for thickness and chamfer of paver block for calculation of compressive strength

(Clause E-5)

Paver Block Thickness (mm)	Correction factor for	
	Plain Block	Chamfered Block
60	1.00	1.06
80	1.12	1.18
100	1.18	1.24
120	1.24	1.30

For other thickness of paver blocks between 60 mm and 120 mm, linear extrapolation of correction factor shall be made.

E-6 REPORT

The individual and average compressive strength of the specimens tested as per E-1 to E-5 shall be reported.

"ANNEX F"**METHOD FOR DETERMINATION OF FLEXURAL STRENGTH****F-1 APPARATUS**

The apparatus used for test shall be the same as in Clause 8 of IS 516 with the following modifications:

- (a) The distance from centre to centre of the two rollers on which the specimen is supported shall be 160 mm.
- (b) The load shall be applied through a single roller mounted on top of the specimen at the centre of the supporting span, i.e., the horizontal distance from the loading point to the centre of each of the supporting rollers shall be 80mm.

F-2 SPECIMENS

This test method can be applied for type A, B and C blocks having minimum length of 180 mm. Five paver block specimens, randomly selected from the group of blocks of specified shape, size and thickness, as per the sampling procedure in 5.0, shall be tested.

F-3 CAPPING OF SPECIMENS

F-3.1 The test specimens shall be capped by one of the methods described in E-3 of Annex E.

F-3.2 Specimens with false joints and surface relief features which are likely to interfere with the test results shall have their surface grounded to plainness before capping and testing.

F-4 PROCEDURE

The test procedure shall be the same as in Clause 8 of IS 516, with the following modifications:

- (a) The load shall be applied along the vertical centre line of the supporting span
- (b) The load shall be applied without shock and increased continuously at a rate such that the extreme fiber stress increases at approximately 7 kg/cm²/min.
- (c) The load shall be increased until the specimen fails, and maximum load applied shall be recorded.

F-5 CALCULATION

Flexural strength of the specimen shall be calculated as follows:

$$f_b = \frac{24 p}{bd^2}$$

Where

- f_b = Flexural strength (N/mm²)
- p = Maximum load (N)
- b = Width of the block (mm)
- d = Thickness of the block (mm)

F-6 REPORT

The individual and average flexural strength of block specimens tested as per F-1 to F-4 shall be reported.

"ANNEX G"**METHOD FOR DETERMINATION OF ABRASION RESITANCE****G-1 APPARATUS**

The following apparatus is required :

- (a) Electric drill (1000 watts minimum, ' WOLF 3814 ' or equivalent),
- (b) Drill bracket, guide bar and guide-bar bracket (' WOLF 0421 ' or equivalent),
- (c) Drill stand and paving-unit clamp welded to base plate,
- (d) Drill stand shaft,
- (e) Dial gauge (calibrated one full revolution = 1mm),
- (f) Chuck and ball race
- (g) Chuck casing with water hose connection , and
- (h) Revolution counter (photoelectric or electronic) to measure total revolutions or rpm of ball-race.

The output of the shaft of the drill shall be set at a speed of between 1000 and 1050 revolutions per minute. When the test drill is rigged, the total sliding mass of the drill and attachments shall be 14.5 kg. with a tolerance of ± 0.25 kg. The test rig shall be maintained in this condition. Before testing, the rig shall be checked to ensure that there are no external factors affecting the sliding mass. The drill-stand shaft and guide bare shall be lubricated to ensure free sliding at all Times.

G-2 SPECIMENS

Five paver block specimens, randomly selected from the group of blocks of specified shape, size and thickness, as per the sampling procedure in 5.0, shall be tested.

G-3 PROCEDURE

G-3.1 The mass of drill and fittings shall be checked for free slide on the drill stand shaft without any obstruction. The dry specimen shall be clamped on the drill-stand base plate. The ball-race shall be placed on the specimen and the chuck shall be lowered on the ball-race. The drill shall be left unclamped on the shaft. A constant rate of water supply to the test surface of the specimen shall be started and maintained to clear the debris formed during abrasion.

G-3.2 The drill shall be run for approximately 3 seconds to seat the ball-race. The dial gauge plunger shall be lowered on the bearing surface of the drill bracket and chuck shall be rotated by hand through one revolution in each direction. The dial gauge shall be set Zero to the mean of the needle reading.

G-3.3 The drill shall be run, stopping it at approximately every 1000 revolutions to measure the penetration. The test shall be continued until the ball-race has completed 5000 revolutions or until the dial gauge has indicated an indentation greater than 1.5mm, whichever occurs first. The indentation shall be measured by rotating the chuck by hand through one revolution in each direction and noting the

mean dial gauge reading. The number of revolutions of the ball-race shall be noted.

Note: If the drill and drill stand appear to wander from side to side causing the ball race to alter its path to the paver block surface, then either the drill has been set at the wrong speed or the guide mechanism is worn and needs replacement. Results from the test are valid only if a clearly defined circular impression has been made on the paver block surface upon completion of the test.

G-4 CALCULATION

The abrasion index of the specimen shall be calculated using the following formula:

$$I_a = \frac{\sqrt{r}}{d_i}$$

Where:

I_a = Abrasion Index (calculated when the ball-race revolutions equal 5000 or the penetration equals 1.5mm, whichever occurs first)

r = ball-race revolutions in thousands

d_i = depth of indentation in mm

G-5 REPORT

The minimum value of abrasion index obtained from the five specimens shall be reported as the abrasion index (I_a -min) of the sample.

G-6 GUIDE FOR CHOICE OF ABRASION INDEX

The Abrasion Index is defined in such a manner that it increases/decreases with the increase/decrease in abrasion resistance. When the purchaser wants to specify values for Abrasion Index, the values given in Table 4 may be taken as interim guide.

Table 4 Suggested values of Abrasion Index
(Clause G-6)

S.No	Traffic (Ref. Table 1)	Minimum 28 Days Abrasion Index
1	Non-Traffic	1.0
2	Light Traffic	1.2
3	Medium Traffic	1.3
4	Heavy Traffic	1.5
5	Very Heavy Traffic	2.0

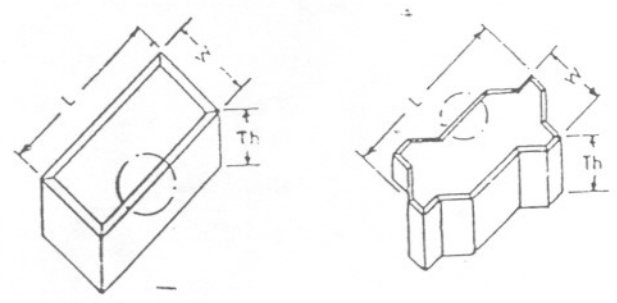
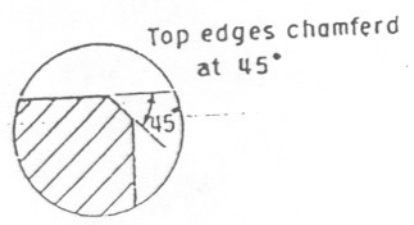

Fig. 3 Length(L), width (W), thickness(T_h) & chamfer (Clauses B-1.3.1 & B-2.3.)

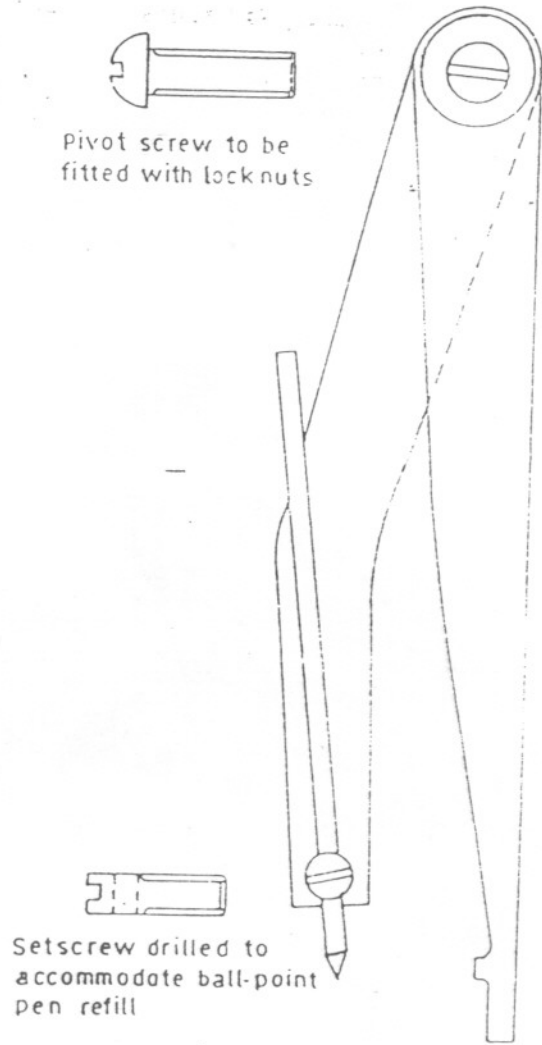

Fig. 4 Odd-leg marking gauge (components & assembly)
(Clause B.3.1)